

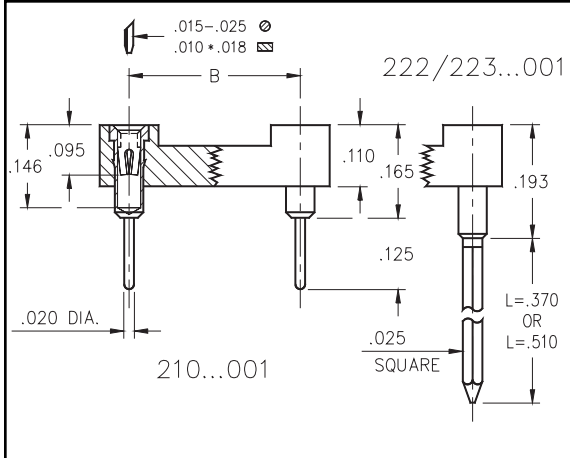

DUAL-IN-LINE SOCKETS Solder Tail and Wrapost Closed Frame

Series 210, 222, 223



- Closed frame insulator with-stands high mechanical impact.
- Available with standard solder pins, 2-level or 3-level wraposts.
- Hi-Rel, 4-finger BeCu #30 contact is rated at 3 amps. See page 208 for details.
- Series 210, 222 and 223 use MM #1001, #0088 or #0089 pins. See pages 134 and 162 for details.
- Insulators are high temperature thermoplastic.

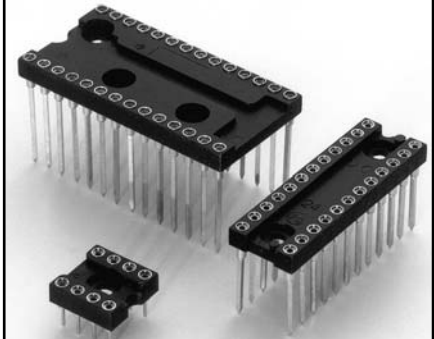

Total number of pins	Pin Spacing			Quantity per tube	Ordering Information		
					Solder Tail	2 Level Wrapost L = .370	3 Level Wrapost L = .510
	A	B	C				
6	0.3	0.3	0.4	67	210-XX-306-41-001000	222-XX-306-41-001000	223-XX-306-41-001000
8	0.4	0.3	0.4	50	210-XX-308-41-001000	222-XX-308-41-001000	223-XX-308-41-001000
10	0.5	0.3	0.4	40	210-XX-310-41-001000	222-XX-310-41-001000	223-XX-310-41-001000
14	0.7	0.3	0.4	28	210-XX-314-41-001000	222-XX-314-41-001000	223-XX-314-41-001000
16	0.8	0.3	0.4	25	210-XX-316-41-001000	222-XX-316-41-001000	223-XX-316-41-001000
18	0.9	0.3	0.4	22	210-XX-318-41-001000	222-XX-318-41-001000	223-XX-318-41-001000
20	1.0	0.3	0.4	20	210-XX-320-41-001000	222-XX-320-41-001000	223-XX-320-41-001000
22	1.1	0.3	0.4	18	210-XX-322-41-001000	222-XX-322-41-001000	223-XX-322-41-001000
24	1.2	0.3	0.4	16	210-XX-324-41-001000	222-XX-324-41-001000	223-XX-324-41-001000
22	1.1	0.4	0.5	18	210-XX-422-41-001000	222-XX-422-41-001000	223-XX-422-41-001000
24	1.2	0.4	0.5	16	210-XX-424-41-001000	222-XX-424-41-001000	223-XX-424-41-001000
24	1.2	0.6	0.7	16	210-XX-624-41-001000	222-XX-624-41-001000	223-XX-624-41-001000
28	1.4	0.6	0.7	14	210-XX-628-41-001000	222-XX-628-41-001000	223-XX-628-41-001000
32	1.6	0.6	0.7	12	210-XX-632-41-001000	222-XX-632-41-001000	223-XX-632-41-001000
36	1.8	0.6	0.7	11	210-XX-636-41-001000	222-XX-636-41-001000	223-XX-636-41-001000
40	2.0	0.6	0.7	10	210-XX-640-41-001000	222-XX-640-41-001000	223-XX-640-41-001000
64	3.2	0.9	1.0	6	210-XX-964-41-001000	222-XX-964-41-001000	223-XX-964-41-001000



XX= Plating Code
See Below

For RoHS compliance
select ◊ plating code.

SPECIFY PLATING CODE XX=	13 ◊	93	43 ◊
Sleeve (Pin)	10μ" Au	200μ" Sn/Pb	200μ" Sn
Contact (Clip)	30μ" Au	30μ" Au	30μ" Au